

Perfect Technology Create Safe Life

4 Beams

Active photoelectric beam detector

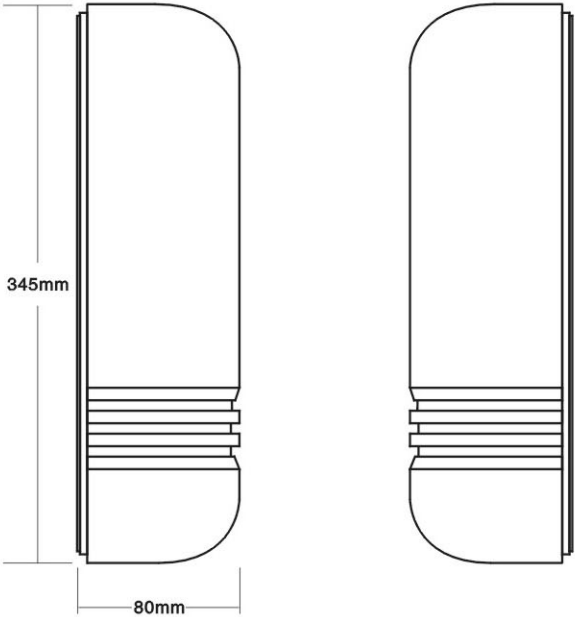

● Exquisite Technology ● High Performance ● Easy Installation

● Reasonable Price ● Quality Service

XA-S Series

1. XA-50S
2. XA-100S
3. XA-150S
4. XA-200S
5. XA-250S

1 Parts List

Check the parts inbox

1. Transmitter (1)
2. Receiver (1)
3. Manual (1)
4. Fix Board (2)
5. U Bracket (2)
6. M3*8mm Screw (6)
7. M4 x 35mm Screw (8)
8. Adjust Viewfinder (2)

2 Part Name

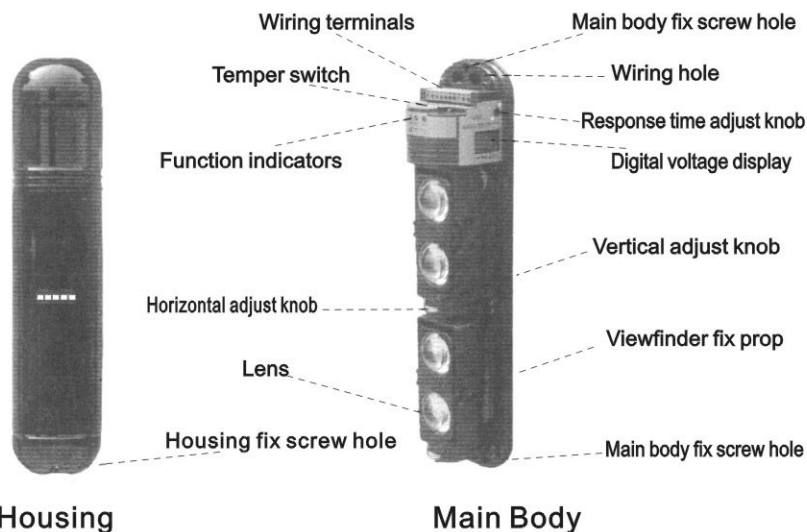

3 Precautions for setting

Multi sensors may be used for long-distance guarding. Please install according to the below diagram to avoid interference between beams

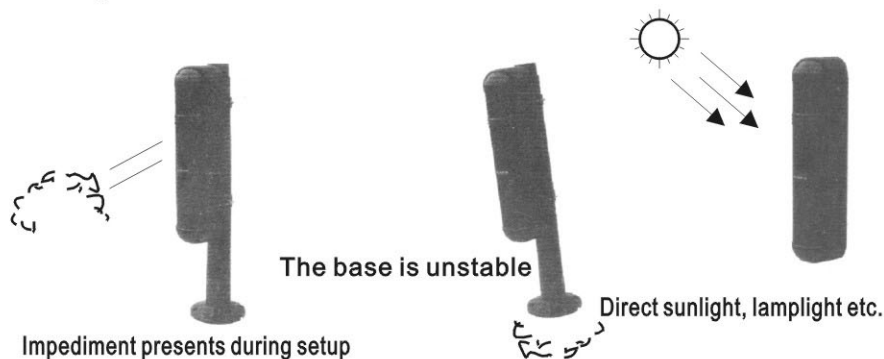

- 2、 Please adopt our props(choose and buy) as to your using environment,
prop diameter: 50mm

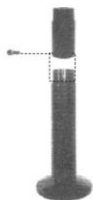

I-shaped prop

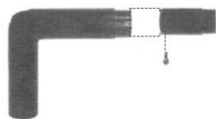

L-shaped prop

- 3、 Using regular diameter props, and make sure it straight.
4、 Fasten the props to the main body ensure the good alignment.
5、 Make sure the transmitter and receiver same straight and level.

4 Fix board

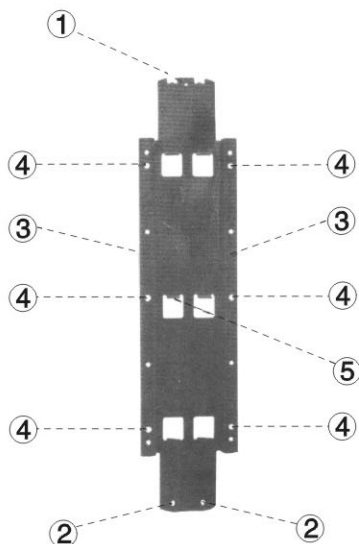

- ① Fix board hole, fix by M3*8mm screws.
② Fix board hole, fix by M3*8mm screws.
③ Two wiring ducts, one for power lines, the other for signal lines
④ U Bracket fix hole, fix by M4*35mm screws.
⑤ Total six fix board prop to avoid the loosen of the main body.

Note:

Please do wiring the ducts through the rubber wiring holes to avoid water leak.

5 Wiring



1) Transmitter Wiring

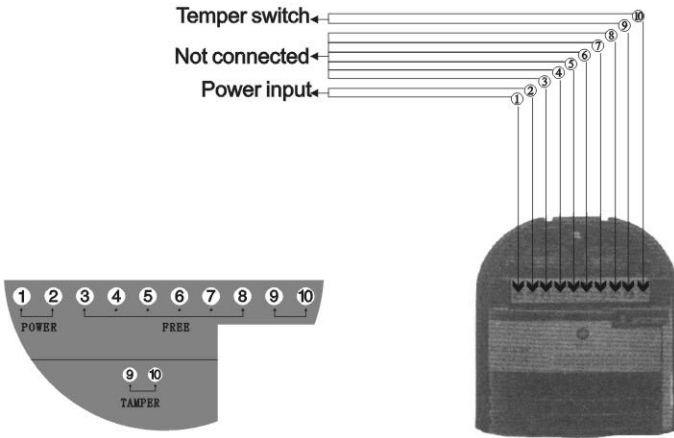

Diagram A Transmitter terminals

2) Receiver Wiring

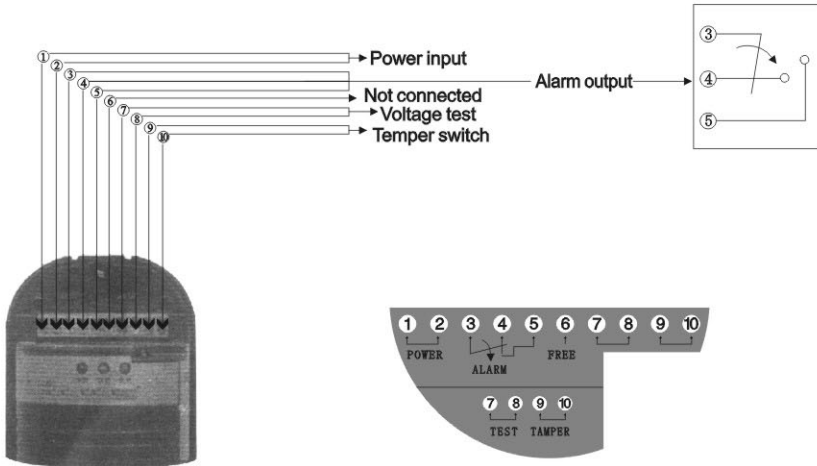

Diagram B Receiver terminals

3) Set wiring

- A. Take off the rubber rings and break through them by the screwdriver.
- B. Pass the wires through the rubber ring holes.
- C. Replace the rubber rings to the wiring holes.
- D. Loosen the terminal screws to open the spacer.
- E. Insert the wires to between the spacers, and fasten the screws.
(Proper the length of the metal wires to avoid wires short)
- F. After testing, seal the rubber holes with glass sealant.
- G. Make sure the power wires and signal wires go separately through the right holes
(Note: Do follow the procedure to avoid water leak)

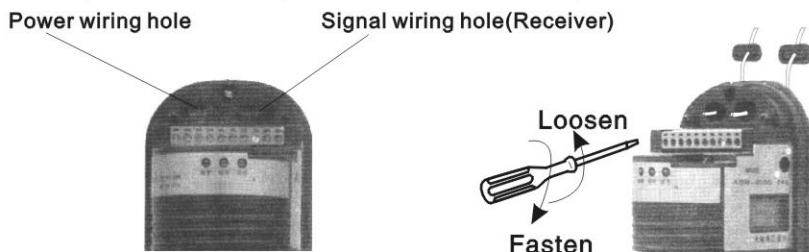

Diagram C

Diagram D

4) Opening the housing

Loosen the housing screw and then uncover the housing



(Note: Take care, don't use too much force or you may break the housing)

Diagram E

5) Pole mounting

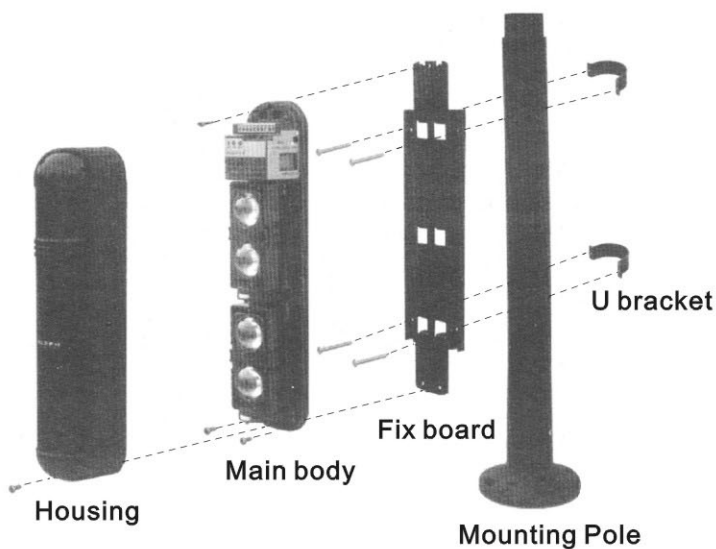

Diagram F

6 Beam adjustment

1) Beam response time adjustment

Please see the diagram to adjust the response time of the receiver. Usually, the time set shall be less than the time when the intruder crosses the guarding area.

The Brightness of the yellow indicator shows the state of alignment



Beam response time adjustment

(Please see the diagram to adjust the response time of the receiver)
 Usually, the time set shall be less than the time when the intruder crosses the guarding area.

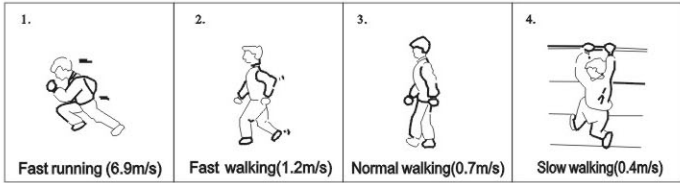
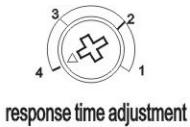

Walking test is required after the setting, physical test in accordance to upper diagram

2) Using of the shade-paper and viewfinder

- A. Adjust the upper and lower optical axis separately.
- B. Observe the collimation effect at a distance of 5cm from the viewfinder. Adjust the upper / lower angle regulation screw and horizontal adjustment wheel in order that the image of opposite detector falls into the central part of the viewing hole.
- C. Mask the upper lens of the transmitter and receiver, Adjust the vertical adjustment screw and the horizontal angle adjusting wheel till the LCD display max(about 3.7V-4.2V) put off the mast and test the upper lens by the same way. Last put off the mast , and the LCD display will be about 4.5-5.0V .

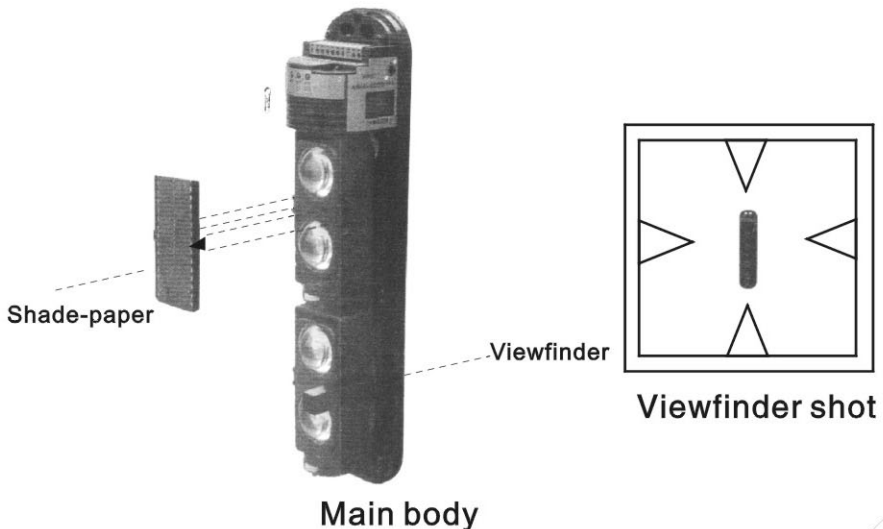

3) Voltage test method

1. After well installed, insert the test pen into the test hole (please note the +,- polarity)
2. First adjust the horizontal angle until the test hole voltage output maximize.
Then adjust the vertical angle by the same way till the output voltage reaches the maximize.

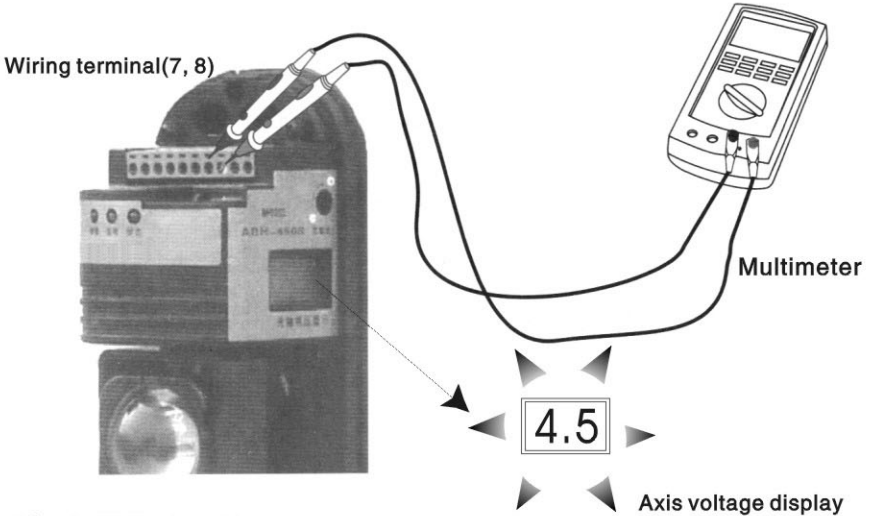

4) LED indicators

	State	Signal
Transmitter	Transmitter	The 2 indicators of green LED light up
Receiver	Guarding	GOOD LEVEL indicators light up
	In alarm	The red ALARM indicator light up

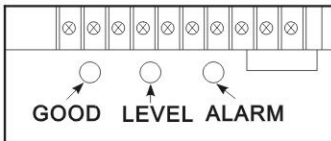

Receiver

- Signal indicator(Yellow)
brightness indicate the signal level
- Alarm indicator(Red)
Turns ON when alarm
- State indicator(Green)
Turns on when working well

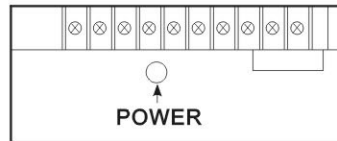

Transmitter

- State indicator(Green)
Turns on when working well

7 Technical parameters



Model		XA-50S	XA-100S	XA-150S	XA-200S	XA-250S
Alert distance	Outdoor	50m	100m	150m	200m	250m
	Indoor	150m	300m	450m	600m	750m
No. of beams	4 beams					
Detection mode	4 beams blocked simultaneous					
Optical source	Infrared digital pulse beam					
Response speed	50 ~ 700msec adjustable					
Alarm output	Relay contact output: NO. NC contact rating: AC/DC30V 0.5Amax					
Power supply	DC12 ~ 20V		AC11 ~ 15V	P \geq 15W		
Power consumption	95mA	100mA	100mA	100mA	105mA	
Operation temperature & humidity	-25 ~ +55°		5%-95%RH(relative humidity)			
Dimensions	Refer to its diagram					
Tamper output	Contact output: NC contact rating DC24V 0.5Amax					
Optical axis adjustment(H)	$\pm 180^\circ$ ($\pm 90^\circ$)					
Optical axis adjustment(V)	10° ($\pm 5^\circ$)					
Additional function	Receiver indicator, voltage LCD display, testing hole					
Protection against dew, frost	Calefaction housing (optional)					
Material	ABS resin					
Net weight	1100g(receiver +transmitter)					
Gross	1800g					



8 Trouble Checking



Fault	Cause	Solution
The LED of the transmitter doesn't light up	Power failure (open circuit, short-circuit, etc.)	Check the power wiring
The LED of the receiver doesn't light up	Power failure (open circuit, short-circuit, etc.)	Check the power wiring
The LED of the receiver doesn't light up when the light is blocked	<ul style="list-style-type: none"> ① By reflecting, or light from other sources enter the receiver ② Both beams are not blocked at the same time ③ Response time is set too short 	<ul style="list-style-type: none"> ① Remove the reflecting object or change the direction of beam ② Block both beams at the same time ③ Prolong the response time
The receiver alarm indicator ON after the beam is blocked, but there is NO alarm signal output	<ul style="list-style-type: none"> ① Broken circuit or short-circuit of the wiring ② Poor contact 	<ul style="list-style-type: none"> ① Check the wiring and contact ② Connect the cable
The alarm indicator of the receiver is constantly ON.	<ul style="list-style-type: none"> ① The beam doesn't match closely ② There is obstacle presents between the transmitter and the receiver ③ The cover is polluted. 	<ul style="list-style-type: none"> ① Re-adjust the beam ② Remove the obstacle ③ Clear the cover
Intermittent alarm signal output	<ul style="list-style-type: none"> ① Improper wiring ② The supply voltage does not reach 13V or higher ③ The potential obstacle appears to block the beams due to the effect of wind and rain ④ The installation base unstable ⑤ The beam coincidence accuracy is inadequate ⑥ Beams blocked by other moving objects ⑦ Response time too short ⑧ The LEVEL LED does not light up before the cover is put on 	<ul style="list-style-type: none"> ① Check the wiring ② Check the supply power ③ Remove the obstacle or change the location ④ Select a site with a stable base ⑤ Re-adjust the optical axis ⑥ Adjust the shade time or the install location ⑦ Re-adjust the response time ⑧ Re-adjust the optical axis, and make the signal reception reaches its top.
Voltage display jump	<ul style="list-style-type: none"> ① Imperfect earth of the switch power shell ② Optical axis misalignment ③ Signal too weak 	<ul style="list-style-type: none"> ① Temper connect to the ground ② Adjust the optical axis ③ replace longer distance detectors

Dealer:

A large, empty rounded rectangular box with a thin black border, intended for entering the name of the dealer. The box is positioned directly below the 'Dealer:' label.